



**HORMA PUMPS
FLUID HOLDINGS
(PTY) LTD**

HP

VERTICAL SPINDLE PUMP



Design Features

- All wetted parts are 28% High Chrome.
- Pump can run dry indefinitely.
- No damage results if the pump is run in reverse due to a keyed impeller.
- Pump is fitted with a mechanical seal which runs in an oil housing allowing for a maximum submersion depth of 990mm.
- Pump has a shaft sleeve and seal flinger designed to keep foreign media from reaching the mechanical seal.
- The suction wear plate is separate from the strainer making maintenance easier and reducing costs on wear parts.





HORMA PUMPS FLUID HOLDINGS (PTY) LTD

HP50

VERTICAL SPINDLE PUMP

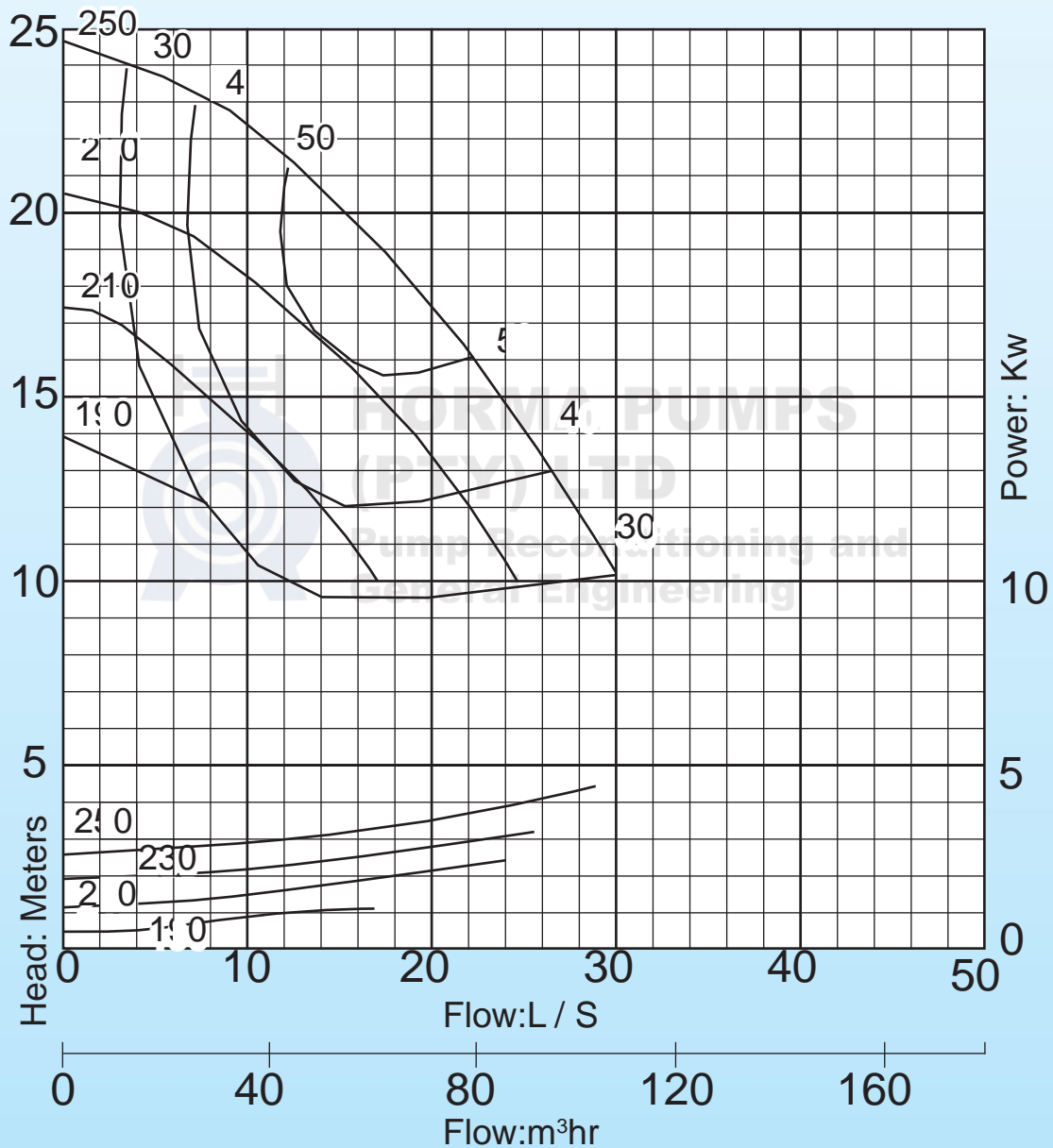

Discharge: 50mm
Impeller Dia: 250, 230, 210, 190mm
Speed: 1450rpm
Kilowatt: 7,5Kw
Volt: 525





HORMA PUMPS FLUID HOLDINGS (PTY) LTD

HP50/250 VERTICAL SPINDLE PUMP

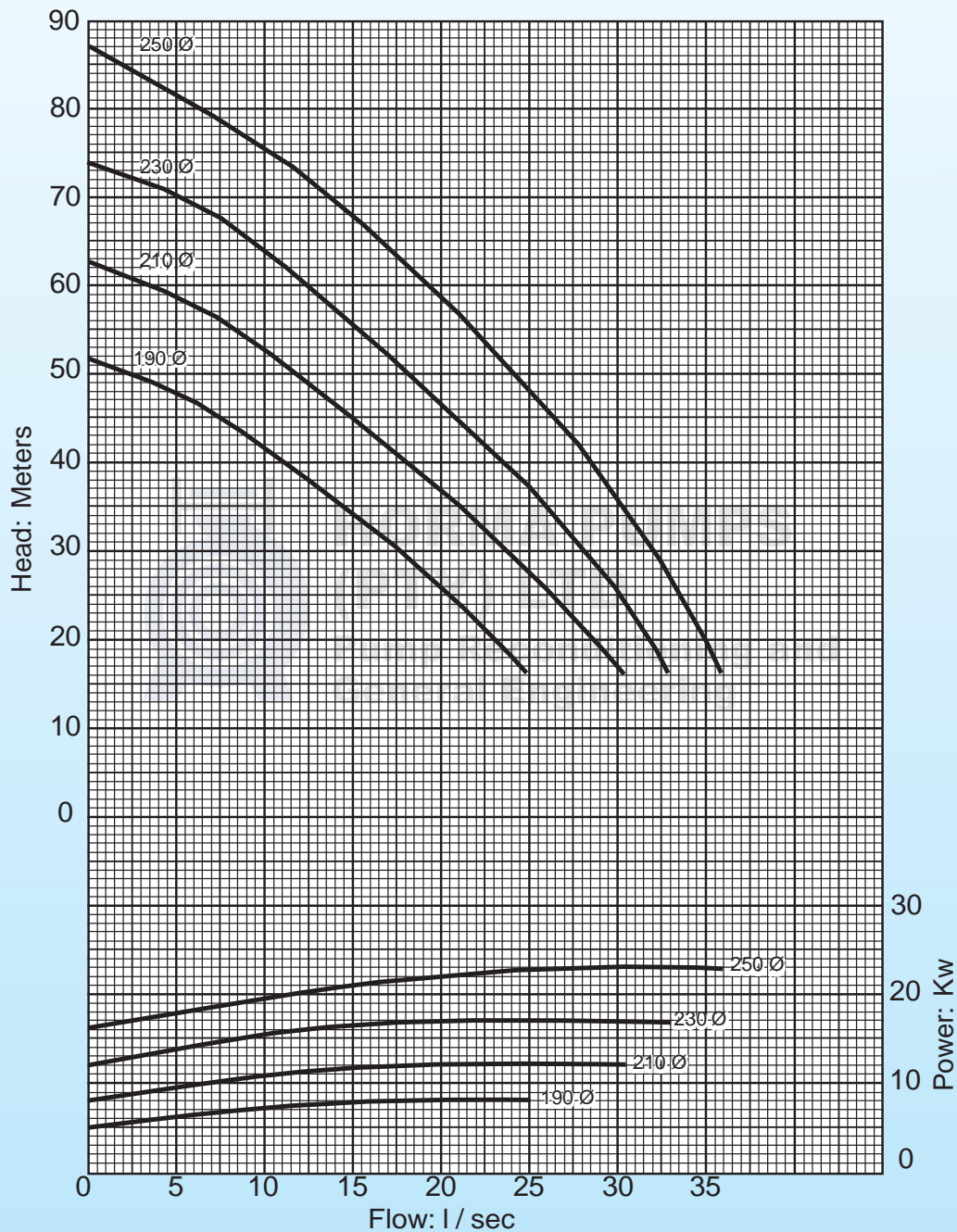

Discharge: 50mm
Impeller Dia: 250, 230, 210, 190mm
Speed: 2950rpm
Kilowatt: 22Kw
Volt: 525





HORMA PUMPS FLUID HOLDINGS (PTY) LTD

HP100 VERTICAL SPINDLE PUMP

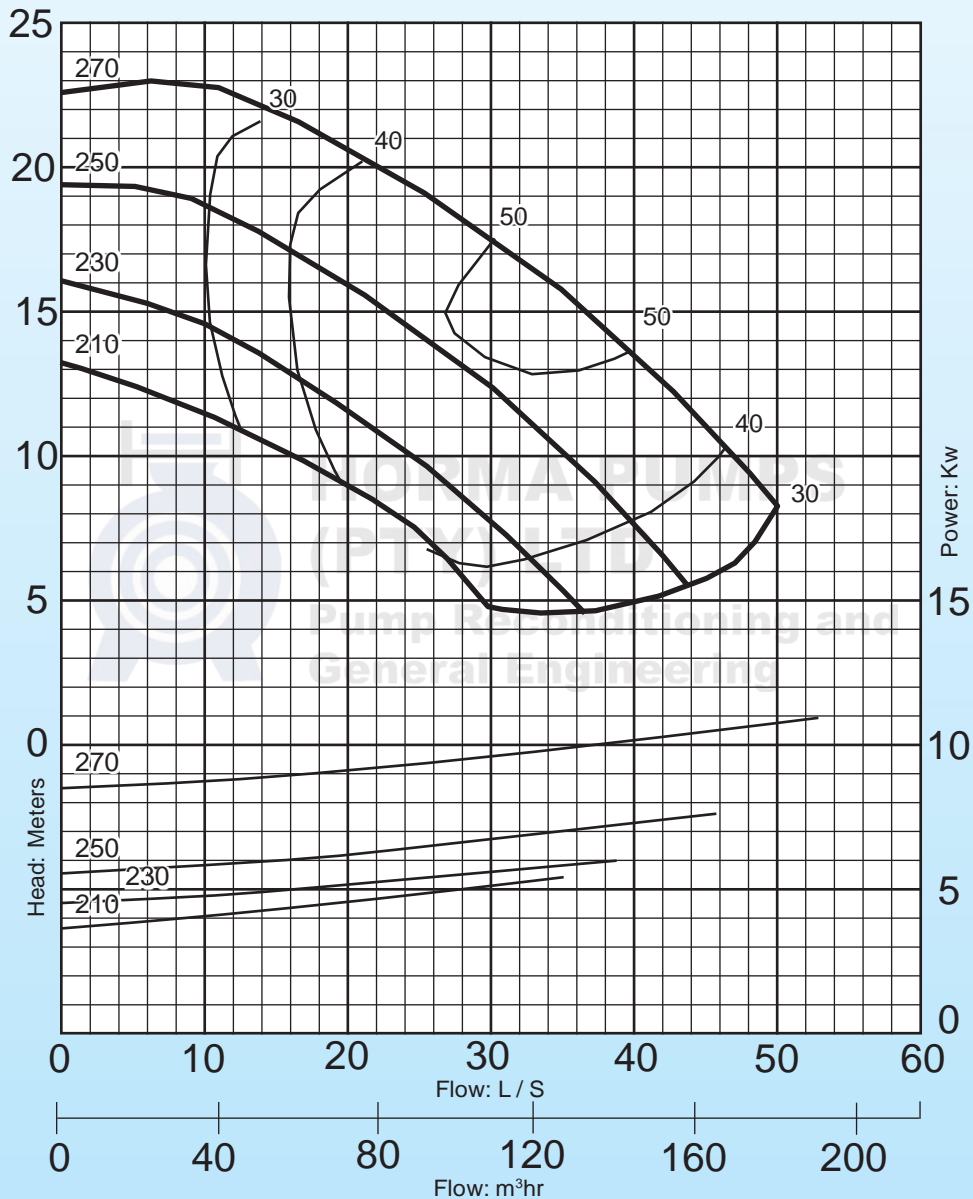

Discharge: 100mm
Impeller Dia: 270, 250, 230, 210mm
Speed: 1450rpm
Kilowatt: 15Kw
Volt: 525





HORMA PUMPS FLUID HOLDINGS (PTY) LTD

HP100 VERTICAL SPINDLE PUMP

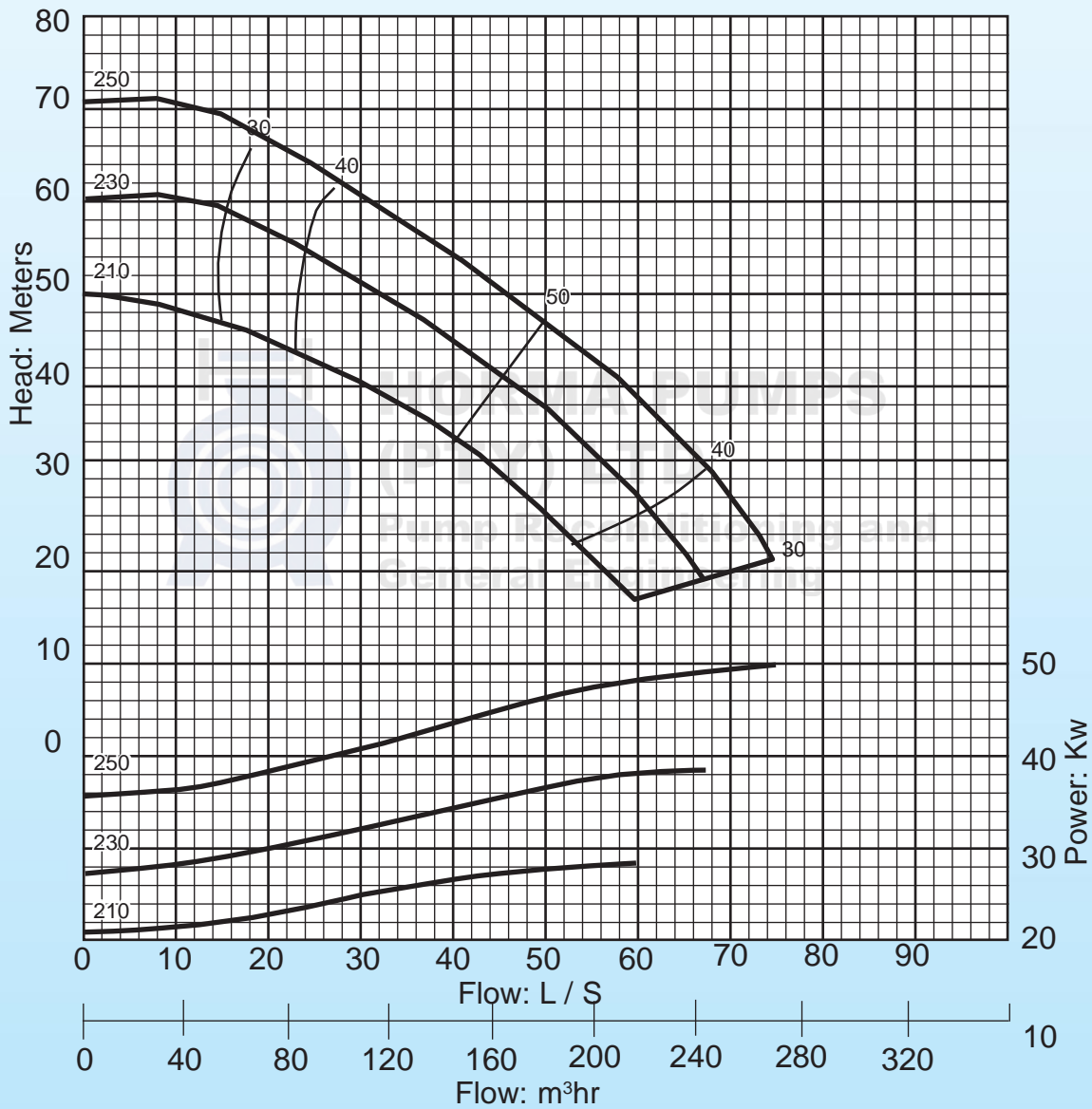

Discharge: 100mm
Impeller Dia: 250, 230, 210mm
Speed: 2900rpm
Kilowatt: 37Kw
Volt: 525





**HORMA PUMPS
FLUID HOLDINGS
(PTY) LTD**



HP50 / 100 VT DIMENSION TABLE

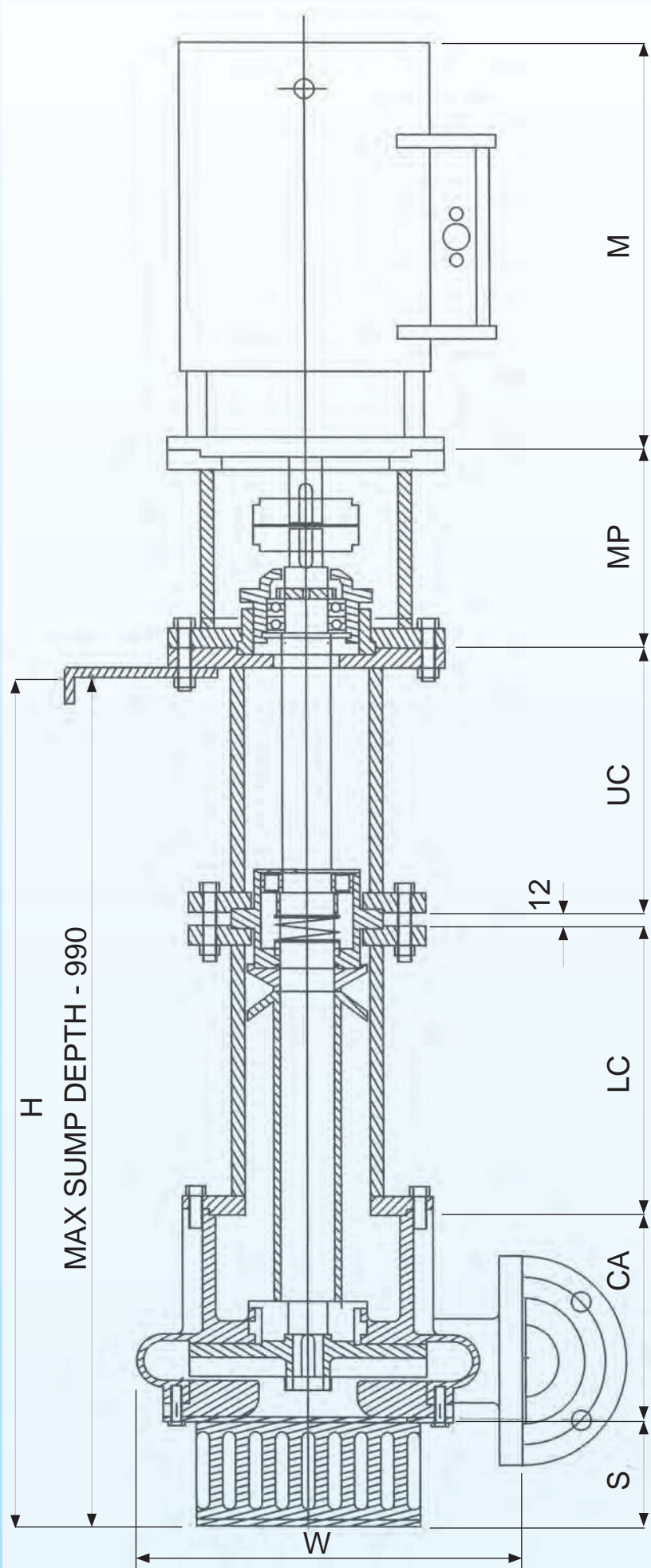

Model	HP50/250/7,5-4P	HP100/270/15-4P	HP50/250/22-2P	HP100/250/37-2P
d	50	100	50	100
D	110	170	110	170
W	375	465	275	465
L	1225	1280	1255	1306
M	450	490	580	700
H	965	990	965	990
MP	260	260	260	260
UC	296	296	296	296
LC	296	296	296	296
CA	210	236	210	236
S	150	150	150	150