

# VACUUM TECHNOLOGY



## HORMA PUMPS (PTY) LTD

Pump Manufacturing, Reconditioning and General Engineering



# Liquid Ring Vacuum

Pump System Consultants • Pump Reconditioning • Vacuum Pump Specialists  
General Plant Maintenance • General Engineers

36 Plantation Road, Eastleigh, Edenvale • PO Box 383, Edenvale 1610  
Tel: 011 452 4300/1 • Fax: 011 452 4400

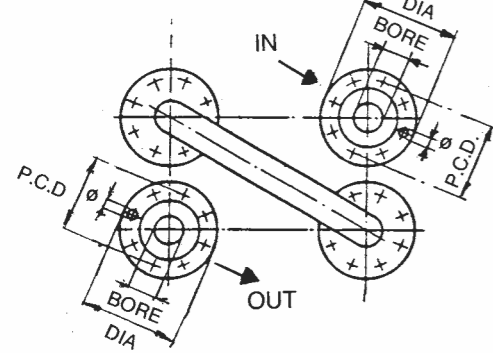
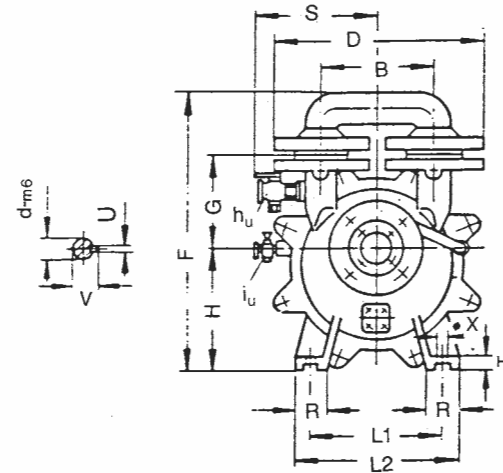
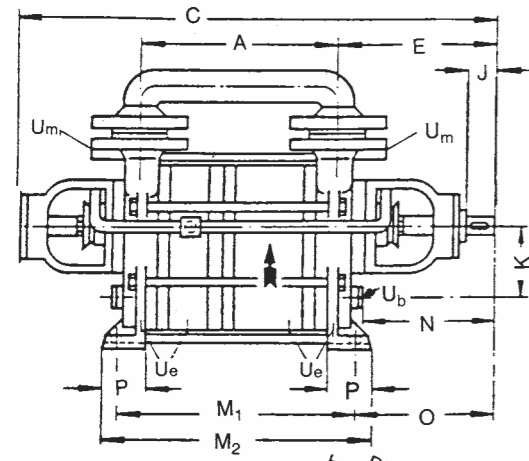

Flanges to DIN 2501 ND 10

Hydraulic Test Pressure 3 bar

U<sub>b</sub> = Service liquid connection

U<sub>e</sub> = Drain plug

U<sub>m</sub> = Connection for vacuum gauge  
(omitted on pumps in materials 42)

h<sub>u</sub> = Air cock (included on pumps in Material 02)

i<sub>u</sub> = Air cock

HP	U <sub>b</sub> Service Conn.	h <sub>u</sub> Air Cock	i <sub>u</sub>	U <sub>e</sub> Drain	U <sub>m</sub> Vac Guage Con
5600	1" BSP	1" BSP	1/4" BSP	1/4" BSP	1/4" BSP
6600	1 1/4" BSP	1 1/2" BSP	3/8" BSP	1/4" BSP	3/8" BSP
7600	2" BSP	1 1/2" BSP	3/8" BSP	1/4" BSP	3/8" BSP
8600	2 1/2" BSP	1 1/2" BSP	1/2" BSP	3/8" BSP	1/2" BSP

Type	A	B	C	D	E	F	G	H	J	K	L <sub>1</sub>	L <sub>2</sub>	M <sub>1</sub>	M <sub>2</sub>	N	O	P	R	S	T	U	dk6	V	X <sub>2</sub>	DIN 2501 ND 10 INLET/OUTLET FLANGE	
HP5612	334		1125										384	434												
HP5616	374	230	1165	395	343	511	190	212	70	122	240	300	424	474	296	318	65	60	248	20	10	36	39.3	15	50. N.B. 4 Holes x 18 x 125 PCD	
HP5620	434		1220										484	534												
HP6616	436	290	1065	490	350	620	225	250	90	150	320	400	500	560	304	318	80	80	328	25	14	45	48.5	18	80. N.B. 4 Holes x 18 x 160 PCD	
HP6624	556		1185										620	680												
HP7620	540		1258										620	700												
HP7630	690	370	1408	590	422	776	275	320	120	180	380	480	770	850	367	382	100	100	362	25	18	60	64.2	18	100. N.B. 8 Holes x 18 x 180 PCD	
HP7640	790		1508										870	950												
HP8635	850		1810										960	1100												
HP8645	1000	500	1960	785	547	1037	370	430	160	310	500	650	1110	1250	455	492	150	150	472	30	25	90	95.3	24	150. N.B. 8 Holes x 24 x 240 PCD	
HP8655	1100		2060										1210	1350												

## Construction Material

Component	Pump model	Code 01	Code 02	Construction Code 42
Body, suction and discharge casings, guide discs.	All models	Cast Iron GG. 25	Cast Iron GR. 14 BS1452 220	BS1504 316C16
Centre bodies	All models	Fab. Mild Steel	Fab. Mild Steel	BS1504 316C16
*Impellers	All models	S.G.Iron	BS1504 316C16	BS1504 316C16
Shaft	HP5612/16/20 6616/24 HP7620/30/40 HP8635/45/55	(EN57) (EN57) (EN9)	BS970 431S29 (EN57) BS970 080 M46	BS970 316S16  BS970 080 M46
Shaft sleeve	HP8635/45/55	(EN8)	BS970 080 M46	BS970 316S16
Gland packing	All types		Soft packing - mechanical seal optional	

## Service liquid requirements

The quantity of service liquid depends on the suction pressure. The flow rates for water are given below in m<sup>3</sup>/h

Suction pressure Operation	40 mbar		70 mbar		110 mbar		150 mbar		210 mbar		350 mbar	
	KB	FB	KB	FB	KB	FB	KB	FB	KB	FB	KB	FB
HP-5612	1,15	(1,9) 3,0	1,1	(1,8) 2,7	1,05	(1,7) 2,5	1,0	(1,6) 2,3	0,9	(1,4) 1,0	0,85	(1,2) 1,5
HP-5616	1,35	(2,2) 3,5	1,3	(2,0) 3,2	1,25	(1,9) 3,0	1,2	(1,8) 2,8	1,15	(1,6) 2,2	1,1	(1,4) 1,7
HP-5620	1,65	(2,7) 4,5	1,6	(2,6) 4,2	1,55	(2,5) 3,8	1,5	(2,4) 3,5	1,35	(2,0) 2,8	1,2	(1,7) 2,2
HP-6616	2,4	(4,3) 7,0	2,4	(4,3) 7,0	2,3	(4,0) 6,1	2,2	(3,7) 5,4	2,1	(3,4) 4,7	1,8	(2,6) 3,4
HP-6624	3,1	(5,3) 8,5	3,1	(5,3) 8,5	3,0	(5,0) 7,4	2,8	(4,6) 6,4	2,7	(4,2) 5,7	2,4	(3,4) 4,2
HP-7620	3,3	(5,6) 8,5	3,3	(5,6) 8,5	3,2	(5,2) 7,4	3,1	(4,8) 6,5	3,0	(4,4) 5,7	2,5	(3,5) 4,2
HP-7630	4,1	(6,4) 9,0	4,1	(6,4) 9,0	3,9	(5,9) 7,8	3,7	(5,4) 7,0	3,5	(4,9) 6,0	2,9	(3,8) 4,4
HP-7640	4,5	(6,9) 9,5	4,5	(6,9) 9,5	4,3	(6,3) 8,3	4,1	(5,8) 7,4	3,9	(5,3) 6,4	3,2	(4,1) 4,7
HP-8635	6,4	(10,2) 14,0	6,4	(10,0) 14,0	6,4	(9,4) 12,0	6,0	(8,5) 10,5	5,7	(7,8) 9,4	4,7	(6,0) 6,9
HP-8645	7,5	(11,5) 15,5	7,5	(11,5) 15,5	7,4	(10,5) 13,5	7,0	(9,5) 12,0	6,6	(8,8) 10,5	5,4	(6,7) 7,6
HP-8655	8,7	(13,5) 18,0	8,7	(13,5) 18,0	8,6	(12,0) 15,5	8,1	(11,1) 14,0	7,7	(10,0) 12,0	6,2	(7,7) 8,8

KB: Partial recirculation of the service liquid. The data shows the water flow requirements when the service water is 3°C (alternatively 1°C warmer than the make-up water supply).  
 FB: Once through service liquid.

## Technical Data

Pump Type	Unit	HP 5612	HP 5616	HP 5620	HP 6616	HP 6624	HP 7620	HP 7630	HP 7640	HP 8635	HP 8645	HP 8655
Normal rotational speed	RPM	1450	1450	1450	1450	1450	960	960	960	735	735	735
Pumping capacity at suction 150 mbar (110 TORR)	m <sup>3</sup> /h	280	345	420	540	780	830	1260	1620	2050	2650	3150
Moment of inertia	kp - m <sup>2</sup>	0,55	0,65	0,82	1,4	2,1	5,0	7,3	8,7	34,0	43,5	49,5
Motor power	kW	11	11	15	18,5	30	30	37	45	75	75	90
Overall dimensions of pump complete with motor and baseplate. Length / width/height	mm	2550/500/590	1590/580/610	1690/580/620	1790/640/710	2020/620/780	2100/660/540	2440/750/940	2610/820/940	3120/950/1240	3270/1000/1240	3490/1090/1260
Mass of pump bare shaft	kg	160	170	180	275	310	500	580	650	1500	1670	1700
Mass of pump with coupling, mounted on baseplate	kg	244	282	292	422	459	668	765	835	1851	1951	2200
Mass of pump with standard motor, baseplate, coupling and guard	kg	358	391	427	592	724	1008	1215	1415	2851	2951	3270
Coupling size "Fentaflex" with taper bushes		F60	F60	F60	F80	F90	F90	F100	F120	F140	F140	F140
Heat absorbed when compressing air from 40 to 1020 mbar	kJ/s	6,2	6,9	8,4	13,5	17,6	19,2	27,9	30,2	45,4	54,6	62,8

## Pumping Capacity and Power Consumption

The data given is for pumping dry air at 20°C with water at 15°C as the service liquid.

Pumps in materials of Code 42 the suction capacity is approximately 10% less than that shown.

